



Patient Observation Camera



Command Projects' Patient Observation Camera is specifically designed to allow staff in the CT control room to closely monitor patient physical appearance during a scan sequence via a 24" wall-mounted monitor on an adjustable arm allowing for optimal viewability.

Our IP camera requires only a single cat 6 cable to be installed and the entire system can be run from a single power point located within the control room, leading to a quick and efficient install.

The system allows for upgrades with the option of extra cameras or HDD for recording functionality.



24inch Patient Observation Monitor



5MP night & day mode camera

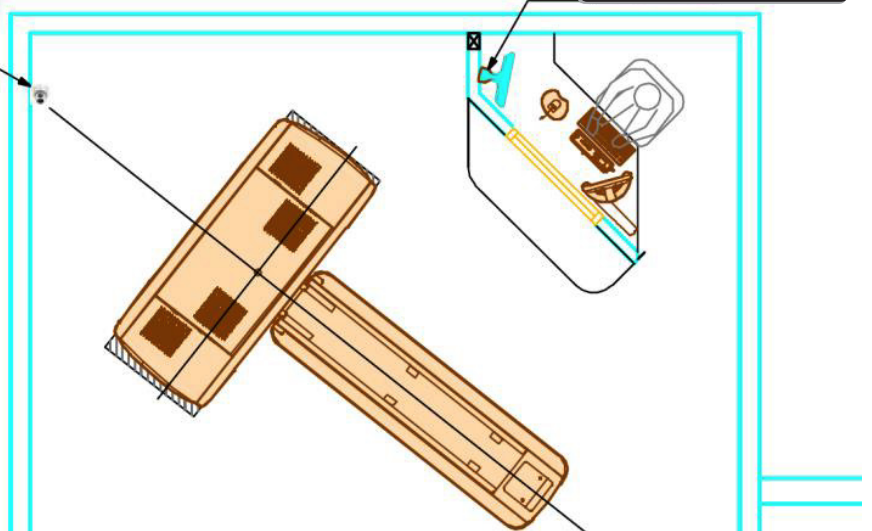

Key Features

- 5MP Day/night functionality
- Smart IR, up to 30m (98ft) IR distance
- 3D DNR (Digital Noise Reduction)
- Support Ultra 265/H.265/H.264 video formats
- 4-channel input
- Plug & Play with 4 independent PoE network interfaces
- HDMI and VGA simultaneous output
- Up to 4K resolution recording
- Easily upgradable

